



PE 500



PE 500

PE 500

PE 500 —

Fanuc

Programmabile Evoluta), LPE (Logica



•PE-500-2TX

(«Z»)

•PE-500-CT2Y

(), «X», «Y»,

PE-500-2TX

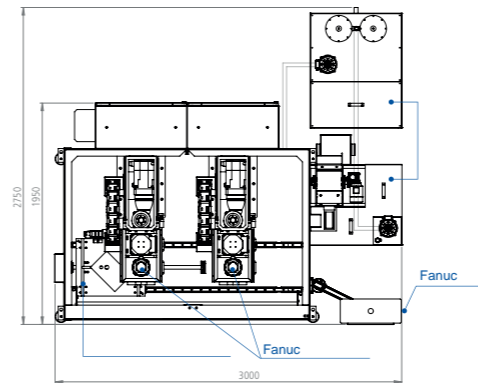

PE-500-CT2Y

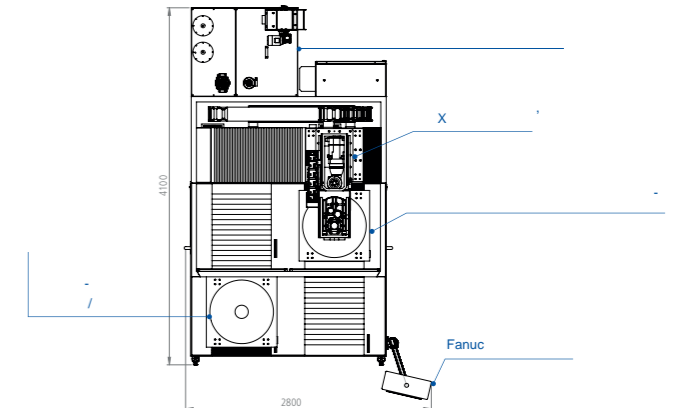

CAR_HoneSoft®

«Z»

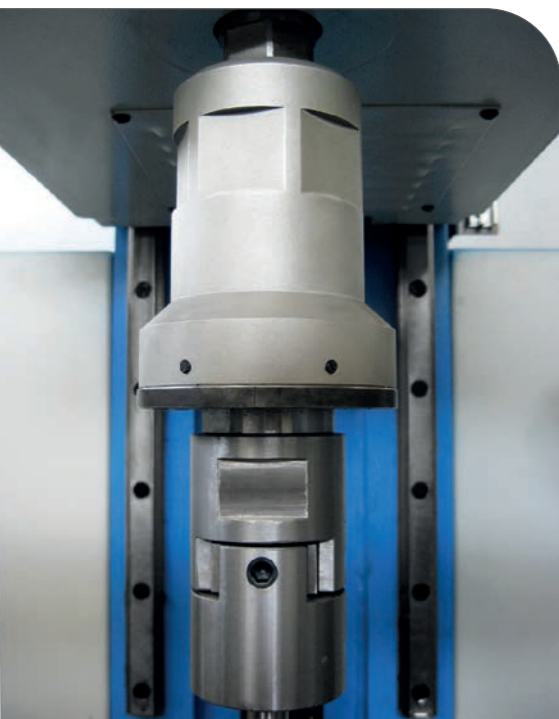

LPS

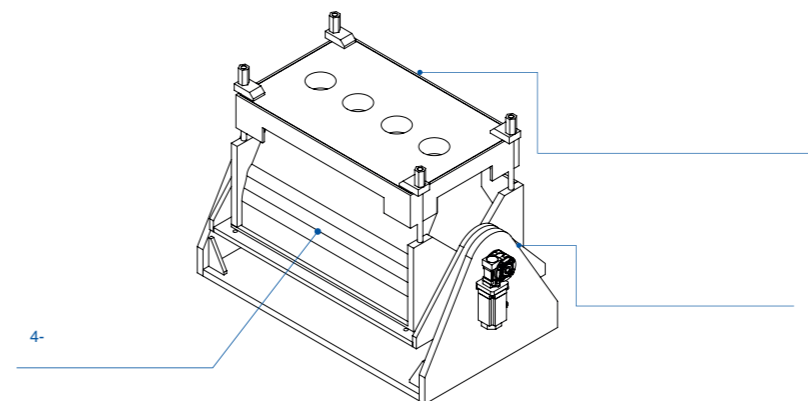

, CN,



J	5,0 ÷ 140,0
	750
	600
	0 ÷ 3.000 /
	30 /
	220
()	1.200 x 1.500 x 3.300
	2.200
	7-10 μ , 10-15 μ